

FAR = GFA / NAL

FAR means the Gross Floor Area (GFA) of all buildings on a site divided by the Net Area of Land (NAL).

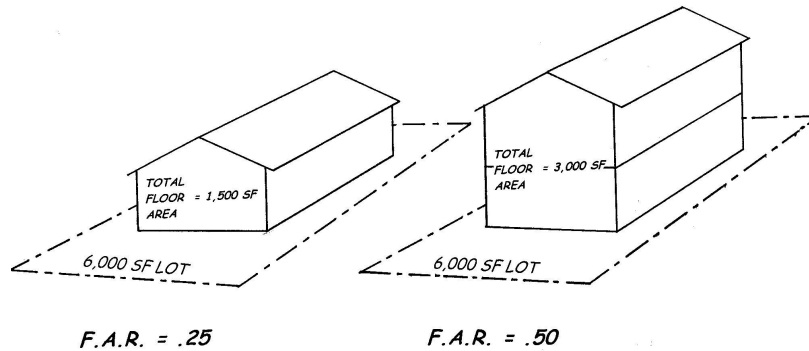

On November 20, 2007, the Town Council adopted a range of FAR values that would allow a higher FAR value of .6 for smaller lots to ensure reasonable livable area, while larger lot would be allowed a .4 FAR. A mathematical formula was developed to transition between the .6 and .4 FAR values. The following schedule reflects the range of allowable residential FAR values:

<u>Lot Size</u>	<u>FAR Formula</u>	<u>Max Floor Area</u>	<u>FAR</u>
-3,000 sf	.6		.6
3,000 sf	.6	1,800 sf	.6
3,500 sf	.6	2,100 sf	.6
4,000 sf	.6	2,400 sf	.6
4,500 sf	.6	2,700 sf	.6
4,600 sf	.6	2,760 sf	.6
4,700 sf	10% of lot +2,300 sf	2,770 sf	.589
4,800 sf	10% of lot +2,300 sf	2,780 sf	.579
4,900 sf	10% of lot +2,300 sf	2,790 sf	.569
5,000 sf	10% of lot +2,300 sf	2,800 sf	.560
5,500 sf	10% of lot +2,300 sf	2,850 sf	.518
6,000 sf	10% of lot +2,300 sf	2,900 sf	.483
6,500 sf	10% of lot +2,300 sf	2,950 sf	.454
7,000 sf	10% of lot +2,300 sf	3,000 sf	.428
7,500 sf	10% of lot +2,300 sf	3,050 sf	.407
7,600 sf	10% of lot +2,300 sf	3,060 sf	.403
7,700 sf	.4	3,080 sf	.4
8,000 sf	.4	3,200 sf	.4
8,500 sf	.4	3,400 sf	.4
9,000 sf	.4	3,600 sf	.4
9,500 sf	.4	3,800 sf	.4
10,000 sf	.4	4,000 sf	.4
+10,000 sf	.4		.4

The **Gross Floor Area (GFA)** of all buildings on a lot for purposes of calculating FAR shall include:

- 1) the total enclosed area of all floors of all buildings measured to the outside face of the walls, as further described below,
- 2) stairways and elevator shafts at each floor,
- 3) the horizontal floor area of attic $\geq 7\frac{1}{2}'$ tall (see diagram below),
- 4) where the top plate or ceiling height (whichever is higher) is 5 feet or more above the grade of the lot measured at the nearest outside building wall, the floor area, finished or unfinished, immediately beneath that affected top plate or ceiling height shall be counted as gross floor area (see diagram below),
- 5) the covered area of a carport,
- 6) enclosed detached garages,
- 7) enclosed detached accessory structures (other than garages), except that the first 120 sq.ft. shall be exempted from the sum total of such structures,
- 8) the covered area of a front entry porch, except that the first 40 sq.ft. of such porch is exempted,
- 9) the horizontal area of a vaulted ceiling $>14'$ in height from floor to ceiling shall be counted as additional GFA (see diagram below), and
- 10) unenclosed structures (such as covered patios) when more than 50% of the exterior sides are enclosed (see diagram below). If such a structure is attached to the main building, the attached exterior side of the main building is not counted.

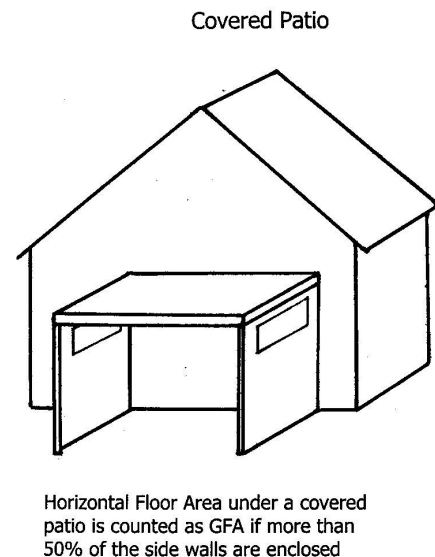
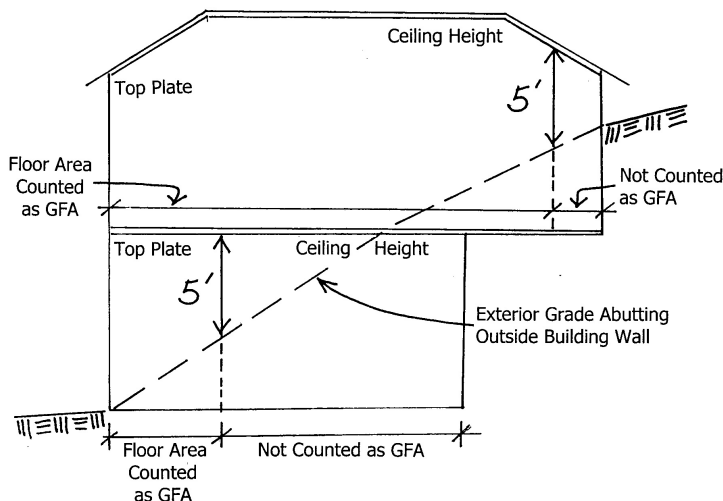
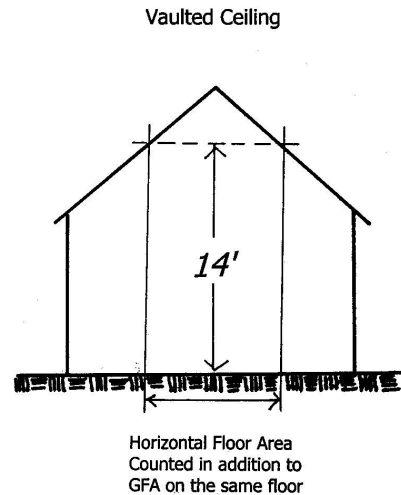
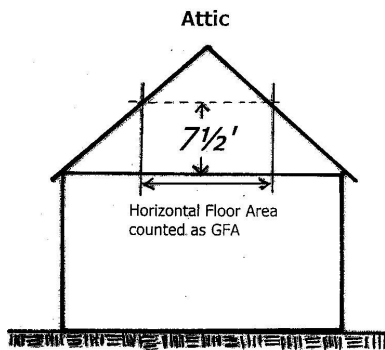

The **Net Area of Land (NAL)** for purposes of calculating FAR shall include the total horizontal area included within the boundary lines of a lot, exclusive of the following:

- 1) Water area within Lagoon No. 1 and Lagoon No. 2 (see aerial below),
- 2) Waterbodies and waterways measured at 6.2 feet NAVD; North American Vertical Datum (see diagram below),
- 3) Dedicated street rights of way,
- 4) The area within easements for roadway, driveway, parking, flood control, pedestrian or bicycle access ways. The Planning Commission or Planning Director shall evaluate the use and visual impact of the easement area should a variance be filed to exceed allowable FAR standards.

